

\* Variable dimension according to the chassis

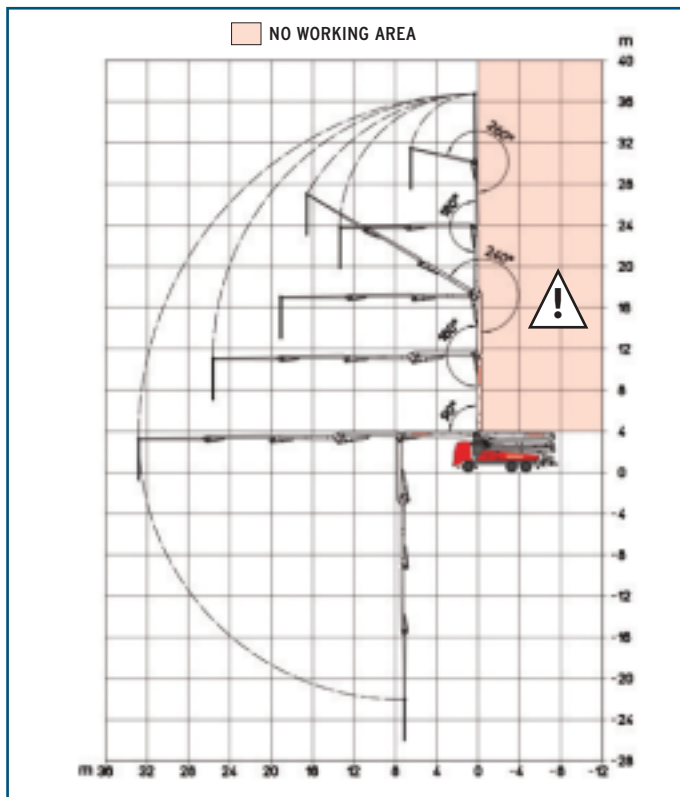

## MAIN FEATURES

- Boom with welded box section, heads obtained directly by cores.
- High torsion rigidity boom stabilization with integrated front and rear outriggers.
- Steel building with high yield tensile strength and structural check of critical points by means of Finite Elements Method (FEM).
- Compact building, reduced weight.
- High functionality and reliability.
- Low operating costs.

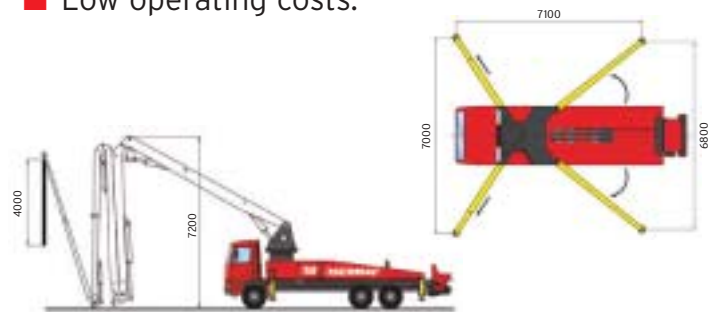

## PUMPING UNIT > technical specifications

Model	SCL130A	SCL150AHP	SCL185A
Concrete output (MAX.) m <sup>3</sup> /h*	130	149	184
Concrete pressure bar*	61	76	61
Pumping cylinders (Ø x stroke) mm	230x2000		
Stroke volume	83,09 l		
Numbers of strokes per min.	26	30	37
Max oil pressure	350 bar		
Hopper capacity	600 l		
Output opening	178 mm		

\* Rod side feeding

## PLACING BOOM technical specifications

Max. height from ground	37 m
Max. horizontal reach	33 m
Max. downward reach	-26 m
Sections number	5
Pipeline diameter	125 mm
Minimum height opening	7,2 m
Flexible terminal hose	4 m
Turret rotation angle	370°
1 <sup>st</sup> , 2 <sup>nd</sup> , 3 <sup>rd</sup> , 4 <sup>th</sup> and 5 <sup>th</sup> section opening angles	90°-180° 240°-180°-266°
Opening system	"Multi Z"
Front outriggers	Telescopic diagonal spread
Rear outriggers	Swing spread
Front opening	7,00 m
Rear opening	6,80 m
Max pressure in circuit	380 bar

## MAIN FEATURES

### SCL CONCRETE PUMP

- System with 2 alternate cylinders and exchange valve
- "S" concrete valve made from an antiwear fusion with different depth, integrated command shaft and fullered profile because of lever command
- Pumping unit provided with automatic lubrication system on the overstraining points
- Automatic system of wears compensation between plate and ring. High wear resistance and max pumping capacity
- Concrete cylinders covered with high resistance and big depth hard chrome
- Chamber made with antiwear steel and an optimal shape to avoid concrete stagnating
- Hydraulic control with automatic sequence, hydraulic driving and continuous power factor correction
- Remote regulation of concrete output, revolutions control, emergency and stop start
- Concrete hopper with high capacity and made of antiwear steel. Mixer shaft with screwed blades
- Field of use: concrete pumping until 1'(K1) slump and max 50 mm size (with Ø 5" pipeline)

### PLACING BOOM

- Boom with "Z" folding type composed of 5 sections in high elastic limit steel, ideal for moving in limited spaces and for working when an high concrete output and a great flexibility in moving are required; 125 mm pipeline
- Hinge points made with double support pin and "Long Life" lubrication
- Hydraulic cylinders made with quick disassembly head without risk of gripping
- Overcenter valves fixed directly on the oil inlet: precise moving and great reliability
- Boom control with proportional distributor to obtain max softness in moving
- Rotation checked by specific reducer for rotation with hydraulic unblocking brake and by block valves plus antishock valves
- Outriggers with front "X" opening and rear swing-out opening with separated driving on both machine sides. Position kept by hydraulic valves
- All controls are made according to conformity of 98/37/CE and UNI EN 12001 concerning safety and wealth

### ASSEMBLY on vehicle

<b>3-axle chassis with short cab</b>	Wheelbase 3.800/4.200 mm
<b>4-axle chassis with short cab</b>	Wheelbase 4.200/4.350 mm
<b>Total mass on ground</b>	Ton. 26/28

## STANDARD EQUIPMENT

- |   |   |
|---|---|
| <ul style="list-style-type: none"> <li>▪ Proportional radio remote control provided with double speed in boom moving, automatic free frequency research, manipulators with 8 positions and output variator</li> <li>▪ Proportional emergency remote control with serial cable</li> <li>▪ Hydraulic pumps with variable displacement and constant capacity adjuster</li> <li>▪ Boom hydraulic pump with variable displacement and "Load Sensing" adjuster</li> <li>▪ Gear hydraulic pumps for service purpose</li> <li>▪ Safety block-out at the opening of tank outlet hatch and hopper grid</li> <li>▪ Pressure gauges and mini flexibles set to supervise the pressure</li> </ul> | <ul style="list-style-type: none"> <li>▪ Membrane or Lobe Water pump 75 l/1', 30 bar</li> <li>▪ Electric vibrator on hopper grid and push-button control panel at distance</li> <li>▪ Water tank in the rear boom stabilizations, capacity 940 l</li> <li>▪ Heat exchanger with hydraulically controlled fan</li> <li>▪ N. 1 light projector</li> <li>▪ Basket for accessories on the hopper side</li> <li>▪ Plates for outriggers support and housing with safety lock</li> <li>▪ Switchboard completely protected on the right side</li> <li>▪ Little ladder to reach the footboard for check and maintenance</li> <li>▪ Tool kit for machine cleaning and maintenance</li> </ul> |
|---|---|

## ACCESSORIES ON REQUEST

- |   |   |
|---|---|
| <ul style="list-style-type: none"> <li>▪ Concrete double wall pipeline with tempered core</li> <li>▪ Additional light projector on hopper</li> <li>▪ Kit high pressure</li> <li>▪ Flashing magnetic base lights to be positioned on the outriggers</li> <li>▪ Pipeline kit for pumping on the ground</li> <li>▪ Multi-level water pump</li> </ul> | <ul style="list-style-type: none"> <li>▪ Automatic release of terminal hose</li> <li>▪ Spare pipe holder on the rear arms</li> <li>▪ High pressure water pump with fan-shaped hose nozzle</li> <li>▪ Atomizer 16 litres, 8 bar</li> <li>▪ Compressor for pipeline cleaning</li> <li>▪ Aluminium cover for hopper</li> </ul> |
|---|---|



**SERMAC S.p.A.**  
 Via Como, 3  
 20054 Nova Milanese (MI), Italy  
 Phone +39 0362 364320  
 Fax +39 0362 364598  
 www.sermacspa.com  
 sermac@sermacspa.com

